



## VisionLine

**The toughest test for hardness.**

10 gf – 3.000 kgf  
Brinell  
Vickers  
Rockwell  
Knoop  
Plastic testing  
Carbon testing  
HBD, HVD

**emco·TEST**

# The new VisionLine.

Test load range from 10 gf to 3,000 kgf in three versions.



**Vision 250**  
Handwheel



**Vision 250-Z**  
Motorized test head



**Vision 250-Z Pro**  
Fully automatic

Test height 175-220 mm

Load range 0.3 - 250 kgf (optional load extension from 10gf)





**Vision 3000**  
Handwheel



**Vision 3000-Z**  
Motorized test head



**Vision 3000-Z Pro**  
Fully automatic

test height 180-350 mm

**Load range 3 - 3000 kgf (optional load extension from 10gf)**



“

The backbone of precision:  
stable yet flexible.

”

# Discover the highlights of the future.

With HumanFocus: innovative technologies and solutions.



More efficient testing processes, less changeover time – thanks to the 8-fold tool changer.

The new tool changer offers maximum flexibility and adaptability. Lenses, indenters, laser, Brinell SmartLight and up to four load extensions can be individually integrated. Work area lighting ensures optimal visibility, even in difficult lighting conditions. The fast-rotating tool changer eliminates the need to change tools for different test methods, increasing efficiency. Customized tool configurations allow for optimal adaptation to your test requirements - for fast and easy testing.

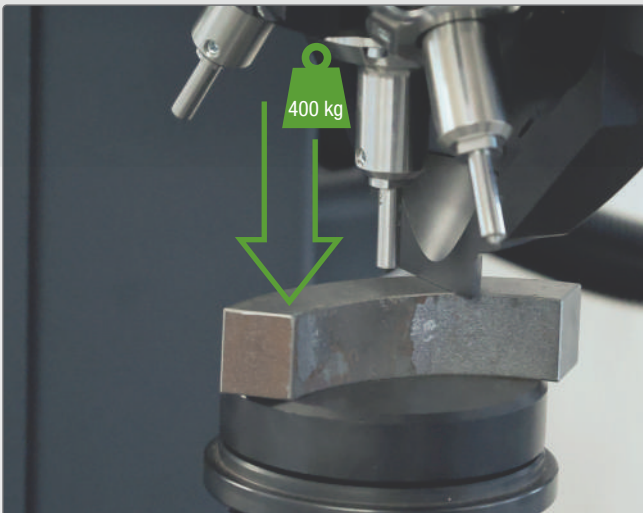

Patented clamping system: stable fixation, precise results.

The innovative design ensures a consistently high clamping force, even at a test load of 3 tonnes, to prevent the component from slipping or lifting. This ensures stable fixation and highly accurate test results.



MotionControl: Ergonomic operation with various control options.

The hardness testing machine offers simple, flexible, safe and ergonomic operation. The functionality of the control unit varies depending on the machine version, but ease of use is always the top priority. With the hand-wheel version, testing starts at the push of a button. For fast positioning, an enabling switch can be used to activate the fast mode. Fully automatic versions also offer an XY joystick for easy sample positioning. Freely configurable software keys add further flexibility. These well-designed features enable efficient and convenient operation, tailored to individual requirements.

## Flexibility for changing test requirements with the load extension down to 10gf.

Many hardness testers are designed for specific test requirements and have limited ability to adapt to future needs. Changing test conditions often require an expensive new purchase. Our hardness testing system offers a clear advantage: the standard load range of 0.3-250 kgf or 3-3000 kgf can be flexibly extended down to 10 gf, even at a later date. This gives you the flexibility to meet changing requirements and saves you the cost of additional machines.



## Easy maintenance, maximum uptime – for uninterrupted productivity.

Modular control revolutionizes maintenance and service with its user-friendly plug-in system technology. Clear interfaces and a well thought-out arrangement of all functional and control components minimize downtime. Easy access for servicing and straightforward component replacement guarantee quick repairs and maximum operational readiness. Thanks to its retrofitting and modernization capabilities, the system offers future-proof flexibility and adaptability for upcoming technologies. Suitable for industrial use and available over the long term, this control solution guarantees lasting reliability and is always up to date.



## ecos™ III - the efficient hardness testing software with artificial intelligence.

Our hardness testing software ecos™ III is specially designed to match the operator's workflows and optimized for easy user guidance and high efficiency. This considerably minimizes the training effort. The test data generated during a test sequence can be individually organized in test orders and clearly displayed and evaluated over longer periods of time. Thanks to the use of artificial intelligence, our software significantly improves image evaluation, thus avoiding incorrect evaluations and manual re-measurements. This ensures reliable inspection results, especially for challenging surfaces.



# Vision 250 & 3000.

Quick & easy testing.



## Status light

The machine status is always clearly visible.



## Handwheel

Quick and easy component positioning.



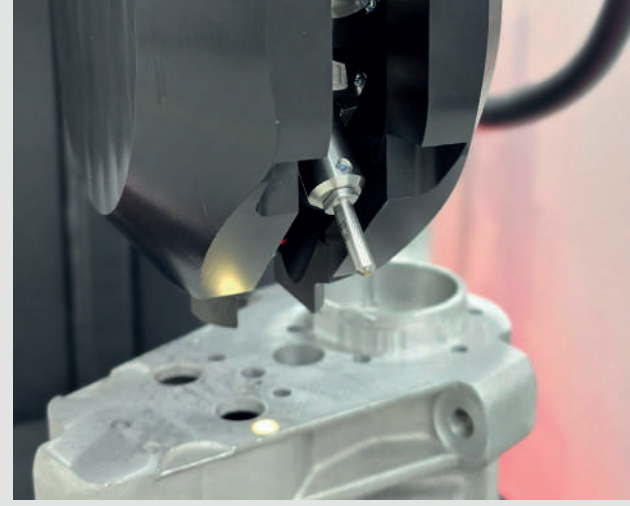
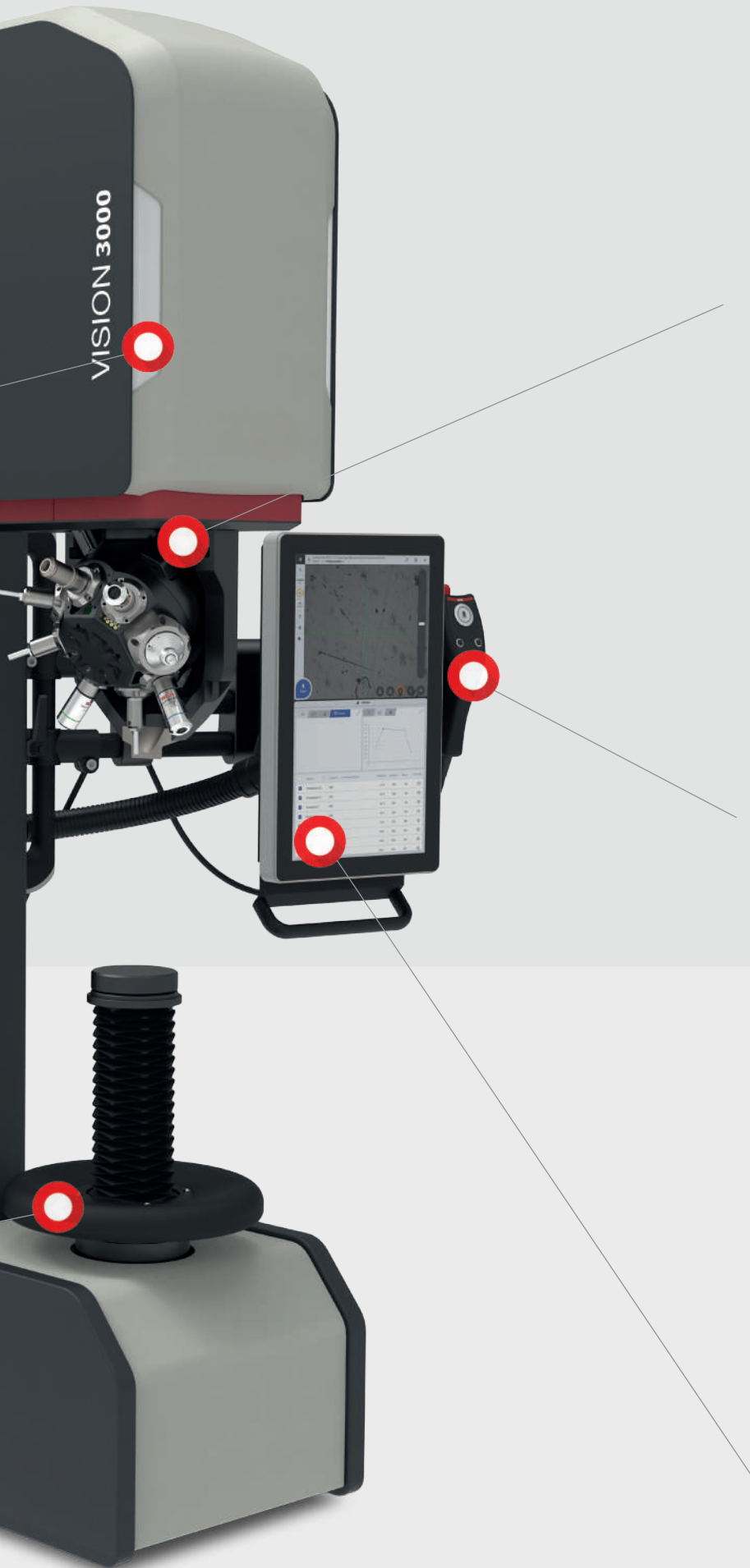

### 3- or 8-fold tool changer

The 3-fold tool changer is ideal for simple applications, while the 8-fold tool changer covers a wide range of applications.



Start measurement

Customizable buttons

### MotionControl - operating unit

Ergonomic and flexible.

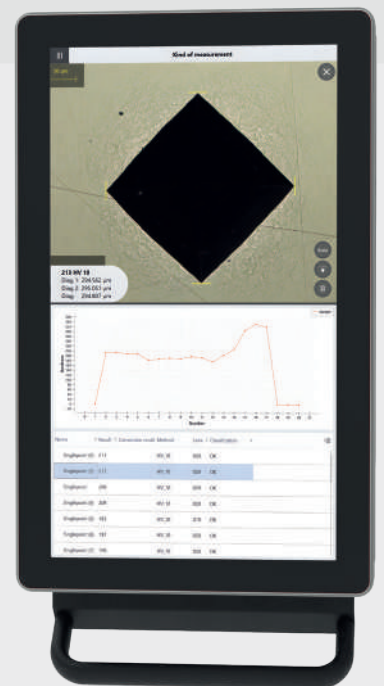

### 15.6" All In One Industry Touch PC

Robust full HD display with integrated industrial PC. Flexibly adjustable for optimal ergonomics.

# Vision 250-Z & 3000-Z.

Universal hardness tester with fast Z-axis.



MotionControl for convenient operation of the Z-axis

Precise results with ease of use – work safely with one hand free.



Stable component fixation thanks to patented clamping system

Constant clamping force for precise results.



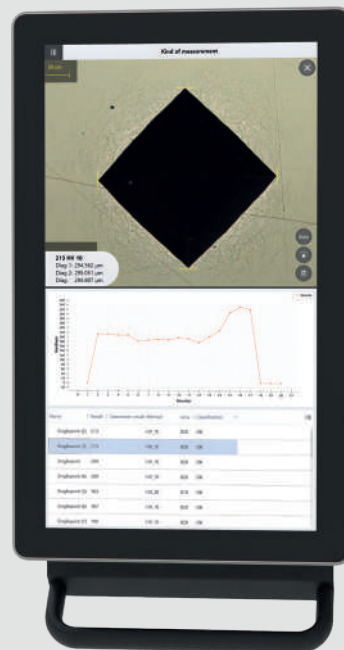
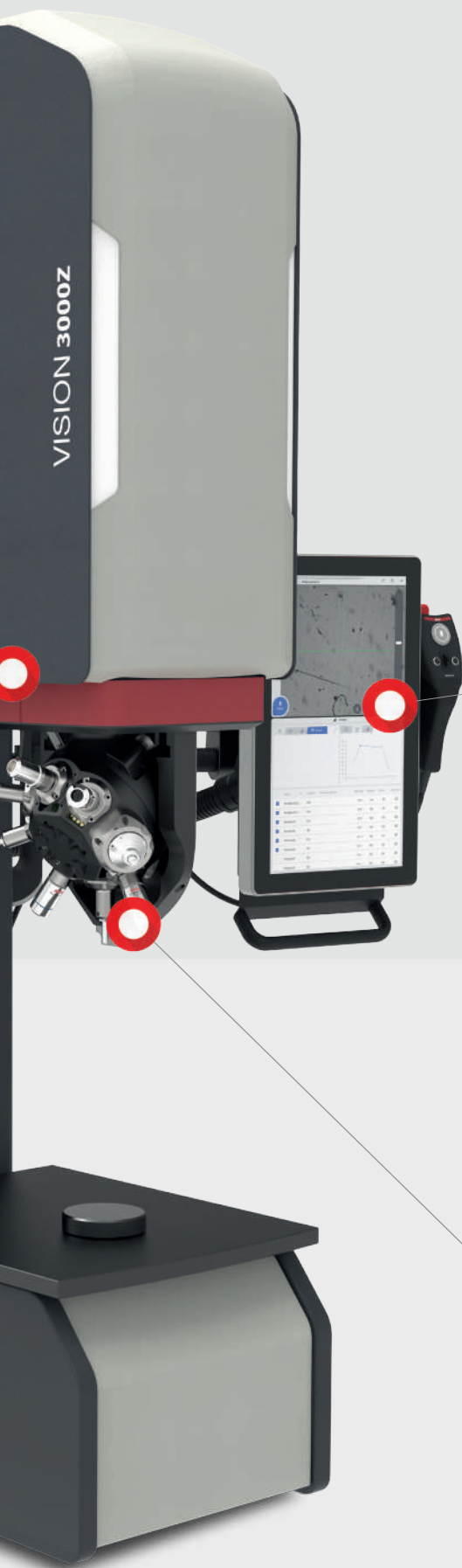

### 15.6" All In One Industry Touch PC

Robust full HD display with integrated industrial PC. Flexibly adjustable for optimal ergonomics.

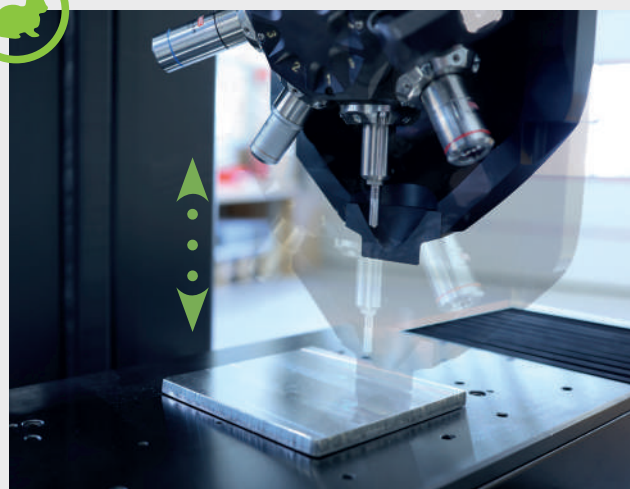

### Quick test head movement

Reduces the time required and optimizes the workflow for components with greatly varying heights.

# Vision 250-Z PRO & 3000-Z PRO.

Automation with the highest precision.

## Maximum safety.



Automatic hardness testing, safe and CE certified without any bulky housing.

## Intuitive operation

It is controlled by an external PC.

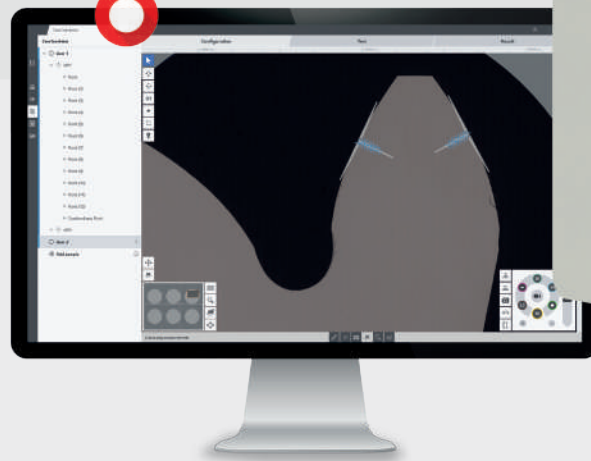

## Clamped and unclamped measurement

Also possible with fully automatic tests.



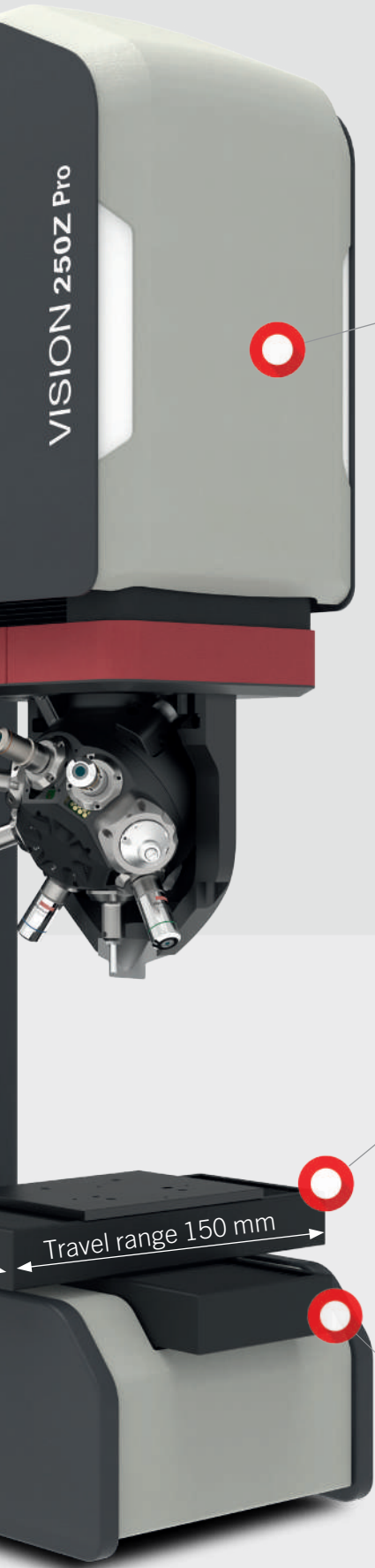

Overview camera

Evaluation camera

### Overview image

The new overview camera provides a large overview image with an extended field of view.



Movement XY-axis

Z-axis movement

### MotionControl PRO

Easy loading of the test table and precise sample positioning using the integrated XY joystick.

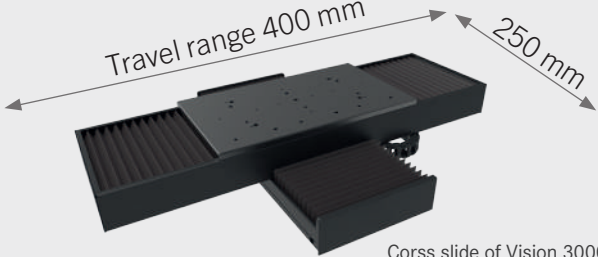

Cross slide of Vision 3000-Z Pro

### Motorized cross slide

For maximum positioning accuracy in fully automated testing.

# ecos™ III Next level efficiency.

The most efficient hardness testing software.

Hardness testing software that exceeds standards.

The new **ecos III** software sets new standards with intuitive operation, a clear overview and maximum efficiency, and offers a completely optimized user experience. Based on years of experience, ecos III provides a unified solution for all devices – whether semi- or fully-automatic. Both versions, Touch and Pro, are based on the same foundation and are perfectly aligned. This is how **ecos III** enables consistent, simple user guidance that feels seamlessly familiar on all devices.

## ecos™ III PRO

For fully automatic hardness testers, **ecos III, Pro** is available with numerous tools for precise positioning of test points and test series. Recurring test settings can be saved as templates and flexibly reused, which significantly increases efficiency and precision. A particular highlight is the option to prepare new orders while the machine is processing test orders. This increases productivity and saves valuable time.

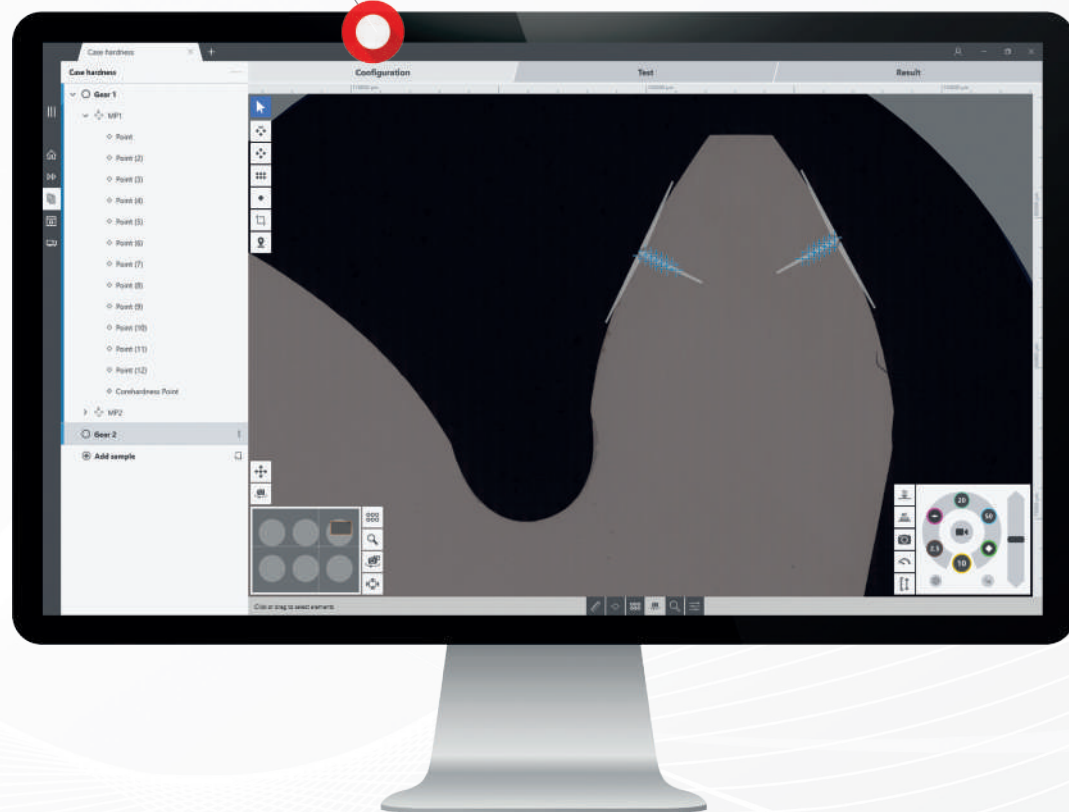

## Efficient

With **ecos III**, you benefit from a well thought-out operating concept in which all the routines have been optimised. This cuts the operating time by up to 65%, and the number of staff required for the test is reduced.

## Simple

Simplicity is at the heart of our hardness testing software. Thanks to the clear, intuitive user interface, users can learn to use the software effortlessly and start using it immediately. Without lengthy training or specialized knowledge, you can quickly obtain accurate test results.

## Clear

For **ecos III**, the overview is the top priority. All test elements are clearly divided into orders and samples. This ensures that the overview is maintained even with large amounts of data, and test reports can be created for several samples, as well as trend analyses.

### ecos™ III TOUCH

The touchscreen version is available for semi-automatic hardness testing and only displays the essentials and individually configurable diagrams and lists.

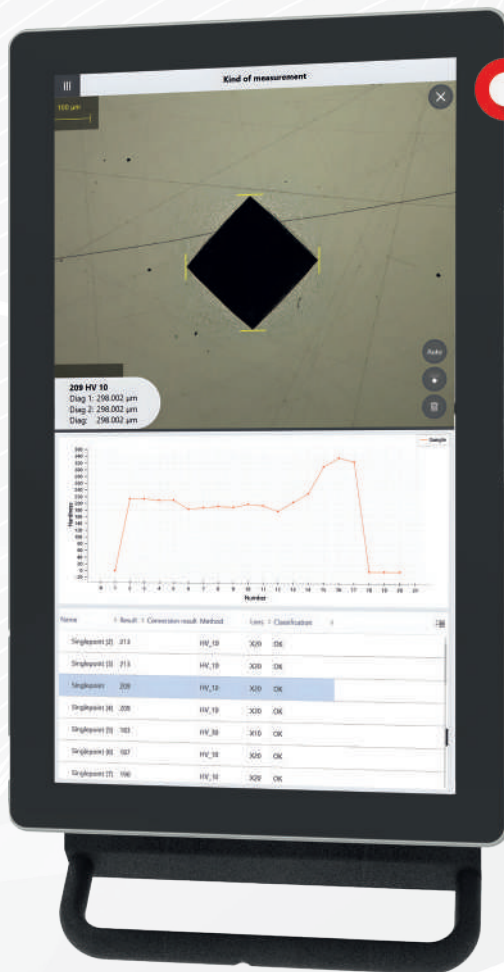

# General software functions.

Efficient basics – standard in every version.

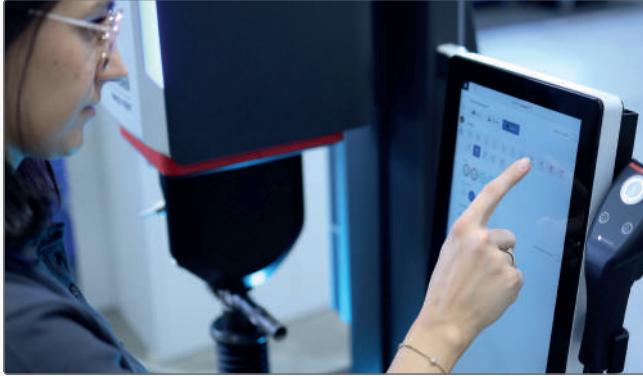

## Minimization of operator influence for reliable test results.

Thanks to the automatic lens selection, the correct lens is always activated to ensure optimal and standardized images. The autofocus ensures fast and precise focusing of the specimen surface, and the image brightness is automatically adjusted. Automatic evaluation takes care of the rest – all without user intervention. If manual re-measurement is desired, this option is still available. The software offers the user maximum support and security for every inspection.

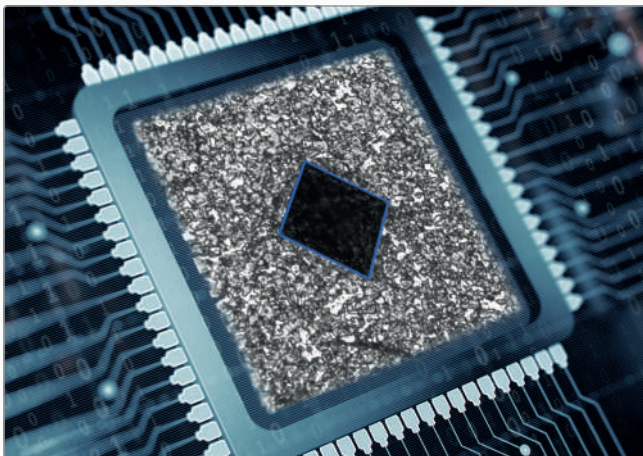

## Improved evaluation of hardness indentation – AI Inside.

The newly developed method for evaluating the hardness indentation is based on artificial intelligence and enables reliable detection even under difficult conditions. Scratches, dirt or etched surfaces, which present challenges for conventional algorithms, are not a problem. The system is available as standard for the Brinell, Vickers and Knoop test methods and delivers precise results in every application. Evaluation on difficult surfaces achieves up to 99% higher accuracy compared to standard evaluations, thus ensuring reliable results.



## Easy administration of user rights – for maximum control and security.

The **eCOS III** operating software enables targeted and flexible assignment of user rights. With the help of an intuitive rights editor, authorizations can be individually defined and, if necessary, secured with password protection. This ensures that only authorized users can perform tests with the desired methods or change machine settings – for more security and control in every application.

## Extensive template mode.

Templates can be easily created for recurring inspection tasks and loaded at any time. This simplifies and accelerates operation, but above all effectively avoids operating and setting errors. Templates can be created for entire samples, series and test specimens.

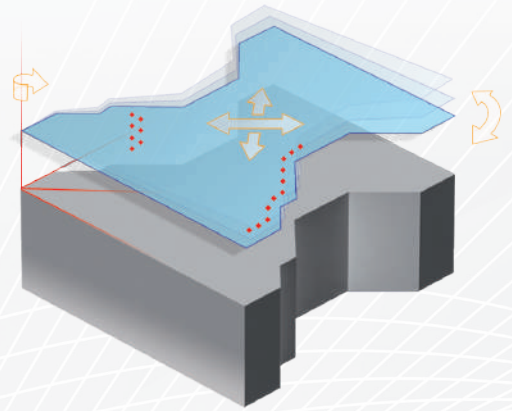

## Organization of the test data.

All test results are grouped into samples. Each sample contains test series and individual hardness impressions. In addition, samples can be bundled into test orders. This structure provides a clear presentation of the test results for each physical sample, which can be displayed in test reports. Jobs also allow you to analyse trends over time or consolidate test data from specific customers or employees. This ensures that you always have a complete overview.

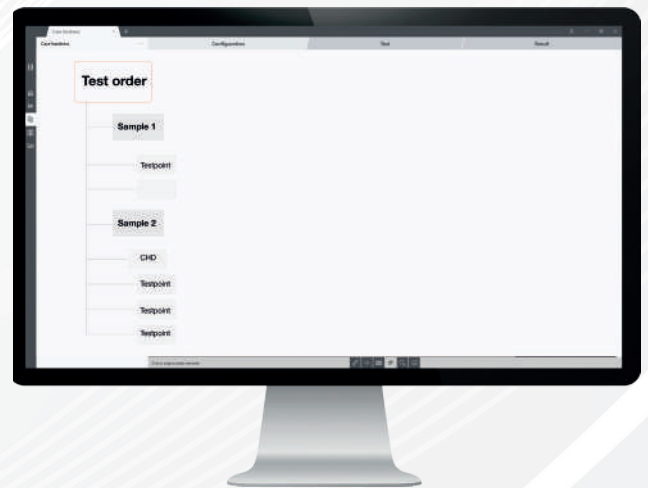

# ecos™ III PRO.

Efficient hardness testing with maximum flexibility.

## Multitasking made easy.

Efficient operation is not only reflected in well-thought-out processes that support the user even in complex tasks, but also in the fact that work does not have to be interrupted when the hardness tester is running and processing samples and common parts fully automatically. Meanwhile, manual test indentations can be remeasured, results evaluated and test reports created. Another advantage is that new test tasks can also be defined at the same time. These can be added to the queue of pending tests or forwarded directly to the semi-automatic machines. This seamless integration optimizes the testing process and ensures efficient and error-free order processing.



## Hardness profiles – simple and fast.

Place any number of test rows on your component quickly and precisely with two clicks per row. Frequently used settings can be saved as templates, which saves additional time and avoids operating errors. Test point patterns can be easily created in the editor or specified using parameters.

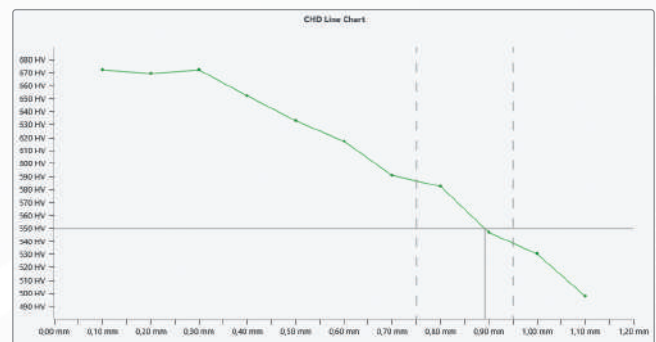

## Just a quick test.

For simple tasks, there is the uncomplicated "Quick Test". Simply define the required method, optionally a conversion factor, and find the appropriate testing centers. The results are displayed in a clear list and can also be printed or exported.

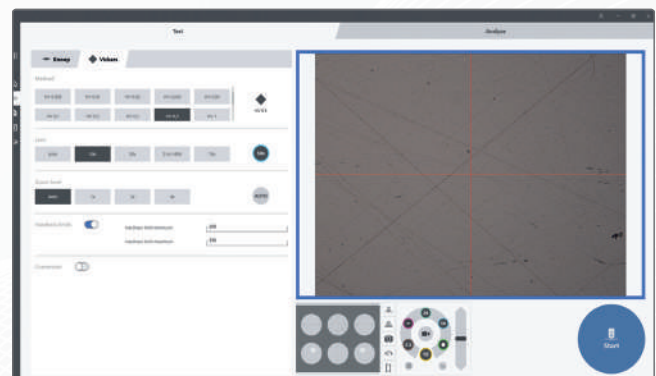

# Hardness testing 4.0

State-of-the-art data management. Simple and safe handling of data.



## Efficient data management.

In addition to the direct creation and central storage of test results, data can be individually exported in various formats such as .pdf, .xls, .csv or .xml. In addition, connections to Q-DAS systems via .dfq files provide seamless integration. Measurement results can be automatically exported to ERP and quality systems, including SAP, Q-DAS, MES and LIMS, supporting efficient and accurate data processing within the internal network.



## Networking in manufacturing.

All Vision models are industry 4.0 leaders and equipped with industrial PLCs to ensure optimal integration into smart manufacturing environments.

# New standards in optics development.

EMCO-TEST revolutionizes image quality and illumination systems.

Precision, image sharpness and colour fidelity at the highest level.

Over a decade ago EMCO-TEST made a landmark decision: to take over the development and production of optical systems for hardness testing machines into its own hands. Since then, the company has set standards in quality, reliability and innovation.

The optical systems have proven themselves in thousands of measuring systems worldwide. This experience has led to the next generation: state-of-the-art optical solutions that combine precision and technological excellence.

The use of high quality components, precise simulations and clean room manufacturing results in complex systems with outstanding image sharpness, uniform illumination and excellent colour reproduction. Newly developed Köhler illumination and finely tuned apertures ensure the best contrast – even at the highest magnifications.



# New optical system: sharper, more contrasty, smarter.

## SmartLight technology for optimal image quality and precision.

Another highlight is the “Brinell SmartLight”, an innovation from EMCO-TEST. This system revolutionized the evaluation of Brinell indentations as soon as it was introduced and has now been significantly further developed. In addition to significantly improved image quality and illumination, it impresses with robust individual components that are specially designed for demanding production environments.

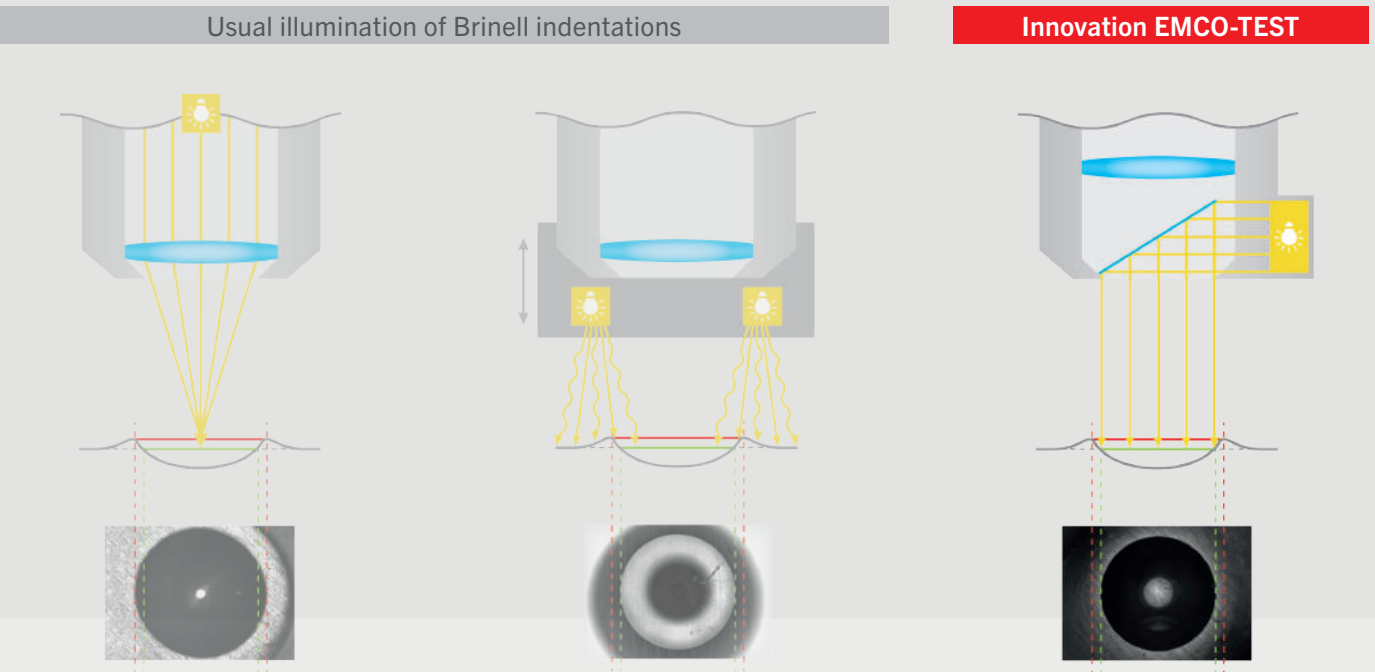

### Coaxial lighting

When using coaxial lighting, the light passing through the lens is scattered on the specimen surface. As the light beams are not reflected back to the lens due to the scatter, the test indentation appears dark. Furthermore, shadowing is caused by the oblique incident light in the area of the bulging around the test indentation. Due to these physical factors, the edges of the indentation are difficult to detect and evaluate.

### Ring light

When using ring lighting, diffuse light falls in a ring pattern from the outside onto the indentation. The light beams are reflected in the test indentation back into the lens. This allows better recognition of the edges compared with coaxial lighting. Depending on the hardness range, different height settings of the circular light are necessary in order to achieve optimum illumination of the test indentation. That these adjustments are performed manually by the operator can, however, have a negative influence on the evaluation result.

### Brinell SmartLight

The SmartLight technology developed by EMCO-TEST combines a lens with “collimated light”. With this lighting, parallel light beams are directed by a mirror system onto the test indentation. The light therefore strikes the test indentation perpendicularly from above and prevents any shadowing in the area of the bulge. The contour is clearly recognisable and the indentation can be precisely evaluated. The SmartLight technology is permanently integrated into the lens and requires no further settings by the operator.

# Options & Accessories.

Maximize your options with accessories for every requirement.



## Ergonomic working with height-adjustable base.

The integrated height adjustment in the base allows the working height to be ergonomically adjusted to the individual requirements of the user. This ensures comfortable and efficient use.



## Optimum clamping for reproducible hardness testing.

Probe inserts play a crucial role in hardness testing by securely fixing and holding down the workpiece. This is particularly important to ensure accurate and reproducible results. Using the appropriate test probe inserts ensures that the test piece remains stable during the test process, which prevents errors caused by movement or vibration. Correct fixturing and holding down of the workpiece thus contributes significantly to the accuracy and reliability of the hardness test.



## Test tables: the key to precise and reliable hardness testing.

Test anvils enable stable and precise positioning of the sample. They also ensure that the test area is plane-parallel to the indenter. Especially for cylindrical parts, they provide secure fixation during the test, which leads to more accurate and reproducible results. Selecting the right test anvil can significantly improve the efficiency and reliability of hardness testing.

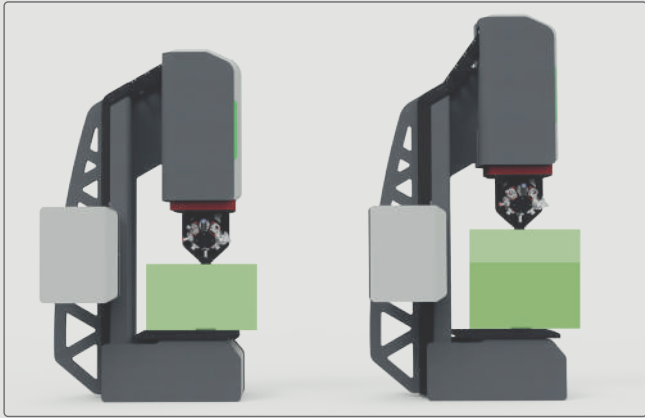

### Test room extension

If the standard test height of the machine is not sufficient, it can easily be extended by 100 mm or 150 mm for particularly large components in the case of Z-machines.



### Ergonomic and User-Friendly Operation

Our machines are designed to support an ergonomic working posture – whether sitting or standing. The keyboard and mouse holder enhances user convenience by ensuring a comfortable and efficient operation.

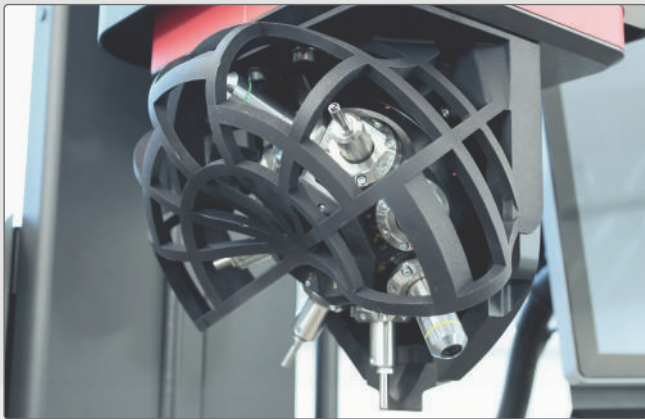

### Tool changer protection

The tool changer guard provides reliable protection for indenters and objectives – ideal for demanding environments or when maximum security is required.



### Handheld scanner

For scanning QR codes. A hand scanner makes it easier to capture test data by quickly scanning QR codes. It enables you to work with hardness testing templates and easily load recurring settings.

More at [emcotest.com](http://emcotest.com)

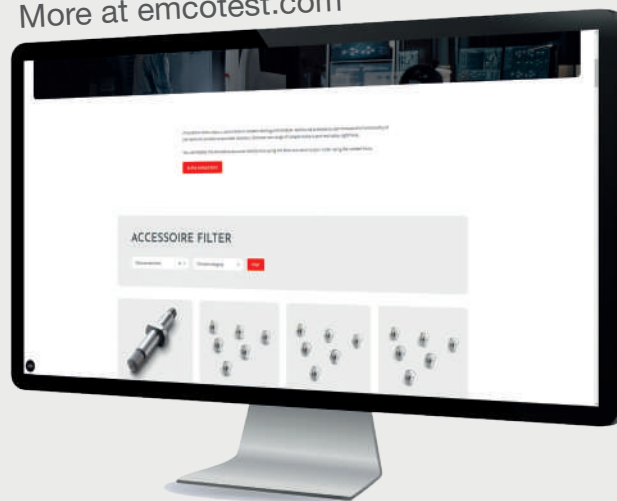

# The backbone of hardness testing for over 70 years.

## Innovative testing: strong partners, strong machines.

### Machines that don't just do everything, but do everything simply.

In keeping with this guiding principle, for decades we have been developing hardness testing machines that make the testing process simple and efficient and provide the user with optimum support for demanding testing tasks. With over 70 years of experience in hardness testing, we are your reliable partner for all hardness testing applications.

For more than 70 years, EMCO-TEST has stood for groundbreaking innovations and outstanding services in the field of classical hardness testing. Through our partnership with ZwickRoell, we now combine 160 years of experience and expertise in materials testing. Our unique product portfolio, which perfectly complements the ZwickRoell range from the beginning of 2021, makes us a strong team. Together, we strive to achieve the highest levels of customer satisfaction and employee engagement as the market leader in hardness testing.

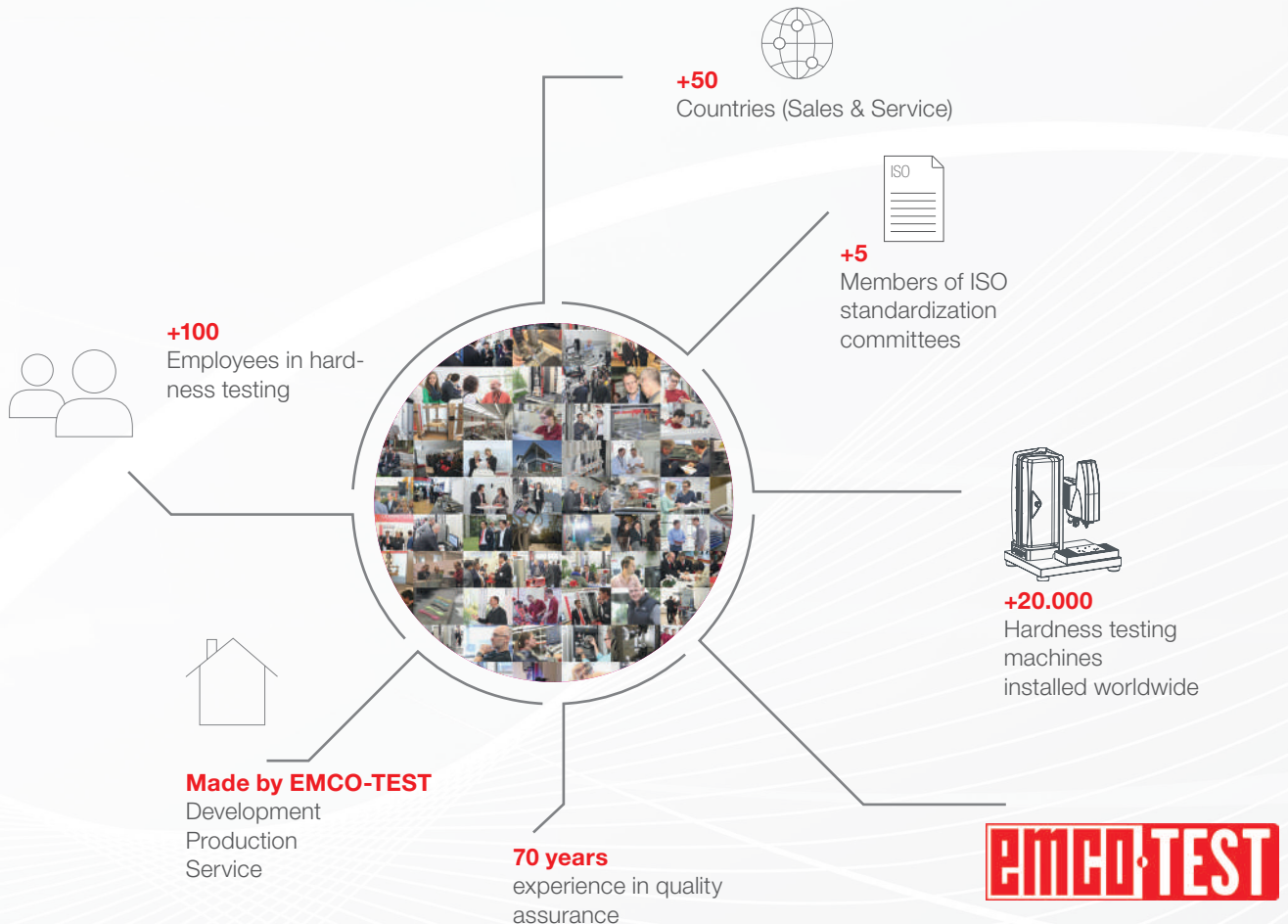

# Overview of test methods.

Precision and efficiency for the intelligent manufacturing of tomorrow.

## TEST METHODS – LOAD RANGE 0.01–250 KGf



### Brinell according to ISO 6506, ASTM E10

1/1	1/2,5	1/5	1/10
1/30	2,5/6,25	2,5/15,6	2,5/31,25
2,5/62,5	2,5/187,5	5/25	5/62,5
5/125	5/250	10/100	10/250
HBD (not standardized)			



### Vickers according to ISO 6507, ASTM E384, E92

HV 0,01 <sup>1</sup>	HV0,015 <sup>1</sup>	HV0,02 <sup>1</sup>	HV0,025 <sup>1</sup>	HV 0,05 <sup>1</sup>
HV 0,1 <sup>1</sup>	HV 0,2 <sup>1</sup>	HV 0,3	HV 0,5	HV 1
HV 2	HV 2,5	HV 3	HV 5	HV 10
HV 20	HV 30	HV 50	HV 60	HV 100
HV 120	HV 125	HV 150	HVD (not standardized)	



### Rockwell according to ISO 6508, ASTM E18

HRA - HRZ	HR15-N/T/W/X/Y
HR30-N/T/W/X/Y	HR45-N/T/W/X/Y



### Knoop according to ISO 4545, ASTM E384, E92

HK 0,01 <sup>1</sup>	HK 0,015 <sup>1</sup>	HK 0,02 <sup>1</sup>	HK 0,025 <sup>1</sup>
HK 0,05 <sup>1</sup>	HK 0,1 <sup>1</sup>	HK0,2 <sup>1</sup>	HK 0,3
HK 0,5	HK 1	HK 2	



### Carbon testing according to DIN 51917

2,5/7	5/7	5/15	5/20	5/40
5/60	5/100	5/150	10/20	10/40
10/60	10/100	10/150		



### Plastic testing according to ISO 2039-1

49,03 N	132,9 N	357,9 N	961 N
---------	---------	---------	-------

## TESTING METHODS - LOAD RANGE 0.01- 3,000 KGf



### Brinell according to ISO 6506, ASTM E10

1/1 <sup>1</sup>	1/2,5 <sup>1</sup>	1/5	1/10
1/30	2,5/6,25	2,5/15,6	2,5/31,25
2,5/62,5	2,5/187,5	5/25	5/62,5
5/125	5/250	10/100	10/250
10/500	10/1000	10/1500	10/3000
HBD (not standardized)			



### Vickers according to ISO 6507, ASTM E384, E92

HV 0,01 <sup>1</sup>	HV0,015 <sup>1</sup>	HV0,02 <sup>1</sup>	HV0,025 <sup>1</sup>	HV 0,05 <sup>1</sup>
HV 0,1 <sup>1</sup>	HV 0,2 <sup>1</sup>	HV 0,3	HV 0,5 <sup>1</sup>	HV 1 <sup>1</sup>
HV 2 <sup>1</sup>	HV 2,5 <sup>1</sup>	HV 3	HV 5	HV 10
HV 20	HV 30	HV 50	HV 60	HV 100
HV 120	HV 125	HV 150	HVD (not standardized)	



### Rockwell according to ISO 6508, ASTM 18

HRA - HRZ	HR15-N/T/W/X/Y
HR30-N/T/W/X/Y	HR45-N/T/W/X/Y



### Knoop according to ISO 4545, ASTM E384, E92

HK 0,01 <sup>1</sup>	HK 0,015 <sup>1</sup>	HK 0,02 <sup>1</sup>	HK 0,025 <sup>1</sup>
HK 0,05 <sup>1</sup>	HK 0,1 <sup>1</sup>	HK0,2 <sup>1</sup>	HK 0,3 <sup>1</sup>
HK 0,5 <sup>1</sup>	HK 1 <sup>1</sup>	HK 2 <sup>1</sup>	



### Carbon testing according to DIN 1917

2,5/7	5/7	5/15	5/20	5/40
5/60	5/100	5/150	10/20	10/40
10/60	10/100	10/150		



### Plastic testing according to ISO 2039-1

49,03 N	132,9 N	357,9 N	961 N
---------	---------	---------	-------

1) Only in conjunction with load extension down to 10g

# Technical data at a glance.

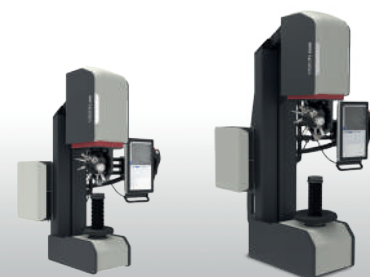

Handwheel

	Vision 250	Vision 3000
<b>Methods and load range</b>		
Load range 2,942-2.452 N (0,3 - 250 kgf) - electronically controlled	•	-
Load range 29,42-29.420 N (3 - 3.000 kgf) - electronically controlled	-	•
Brinell (ISO 6506, ASTM E10)	•	•
Vickers (ISO 6507, ASTM E384, E92)	•	•
Rockwell, Super Rockwell (ISO 6508, ASTM E18)	•	•
Knoop (ISO 4545, ASTM E384, E92)	•	-
Plastics testing (ISO 2039-1)	•	-
Carbon testing (DIN 51917)	•	•
<b>Configuration</b>		
15.6" All In One Industry Touch PC	•	•
Operating software <b>ecos™ III Pro</b>	-	-
Operating software <b>ecos™ III Touch</b>	•	•
Automatic test cycle with brightness control, autofocus and image evaluation	•	•
3 step zoom	•	•
12 Mpix evaluation camera with CMOS sensor	•	•
13 Mpix overview camera with autofocus	-	-
Machine control via integrated PLC	•	•
Motorised height adjustment of the test unit with rapid traverse	-	-
Clamping system	-	optional
Automatic 3-fold tool changer	•	•
Automatic 8-fold tool changer	optional	optional
Workspace lighting	•	•
Testing clamped/unclamped	•	•
Test table (W x D)	Ø 90 mm	Ø 90 mm
Operating system Windows 11	•	•
<b>Functional dimensions</b>		
Max. workpiece weight	200 kg	200 kg
Max. speed on Z-axis	-	-
Max. test height	220 mm	350 mm
Weight of basic unit	240 kg	420 kg
Room temperature (to ISO/ASTM)	+5°C to +40°C	+5°C to +40°C
Humidity	max. 70% (non-condensing)	max. 70% (non-condensing)

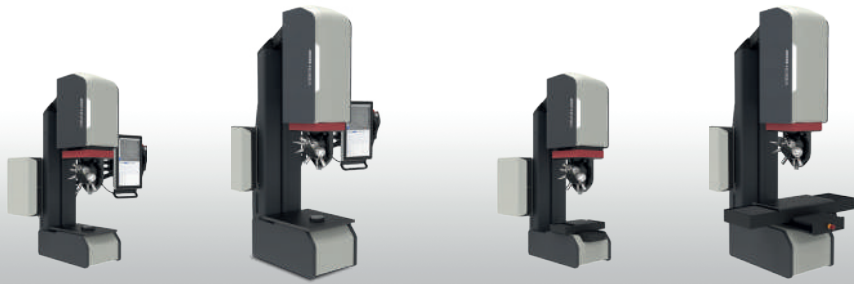

Motorized test head

Fully automatic

Vision 250-Z	Vision 3000-Z	Vision 250-Z Pro	Vision 3000-Z Pro
•	-	•	-
-	•	-	•
•	•	•	•
•	•	•	•
•	•	•	•
•	-	•	-
•	-	•	-
•	•	•	•
•	•	-	-
-	-	•	•
•	•	-	-
•	•	•	•
•	•	•	•
•	•	•	•
-	-	optional	optional
•	•	•	•
•	•	•	•
•	•	•	•
•	•	•	•
optional	optional	optional	optional
•	•	•	•
•	•	•	•
Ø 90 mm + 390 x 295 mm	Ø 90 mm + 370 x 447 mm	150 x 150 mm travel range	400 x 250 mm travel range
•	•		
200 kg	200 kg	50 kg	50 kg
up to 25 mm/sec	up to 25 mm/sec	up to 25 mm/sec	up to 25 mm/sec
175 mm	300 mm	175 mm	180 mm
240 kg	425 kg	260 kg	450 kg
+5°C to +40°C	+5°C to +40°C	+5°C to +40°C	+5°C to +40°C
max. 70% (non-condensing)	max. 70% (non-condensing)	max. 70% (non-condensing)	max. 70% (non-condensing)

# Dimensions

Vision 250:

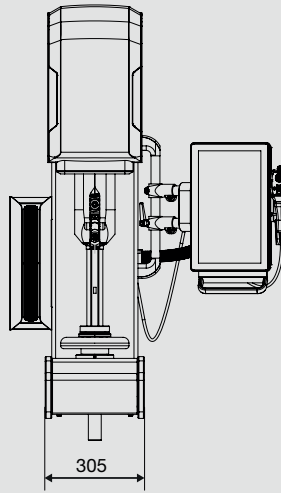
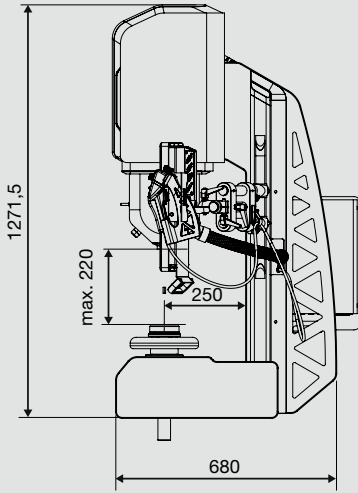

Vision 250-Z:

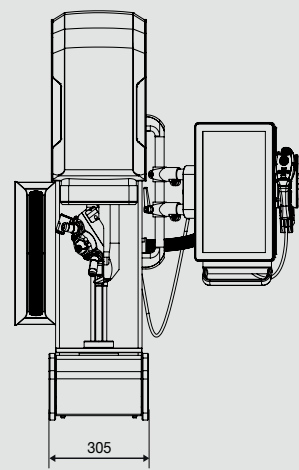
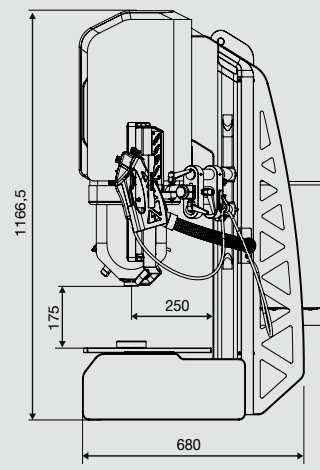

Vision 3000:

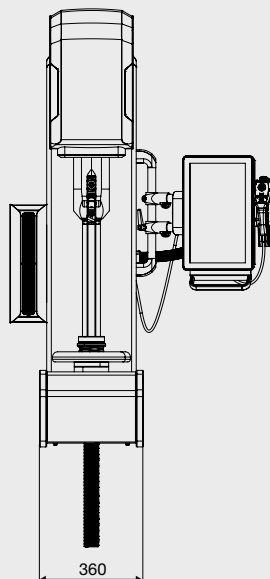
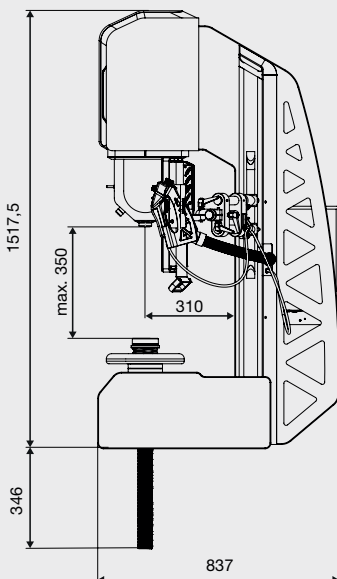

Vision 3000-Z:

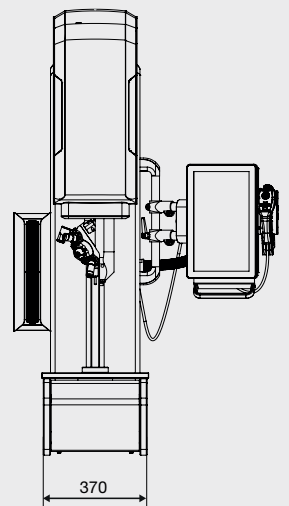
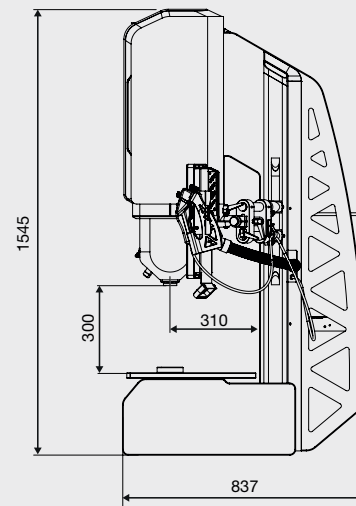

### Vision 250-Z Pro:

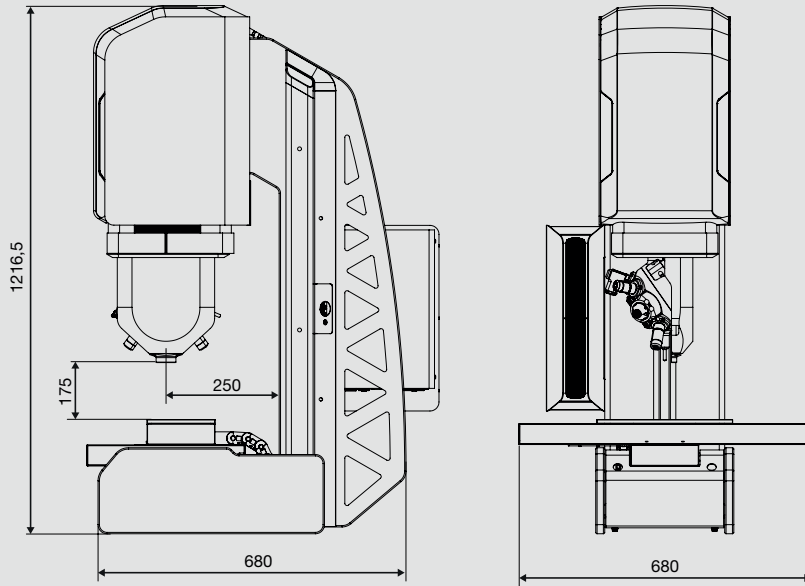

### Vision 3000-Z Pro:

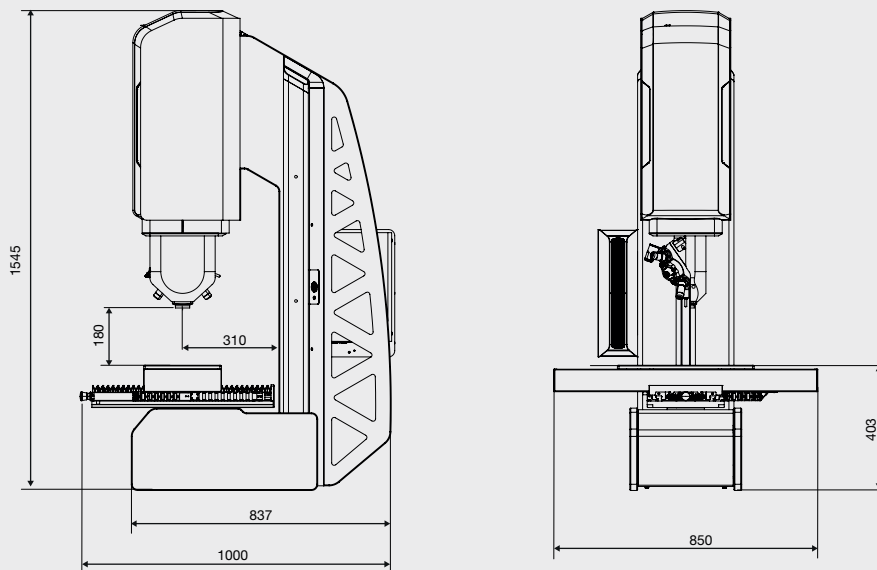

Technical and design modifications as well as printing and typesetting errors reserved. Deviations from the illustrations in colour and form reserved. In some cases the machines/equipment illustrated or described include special options that are available only at additional charge. The equipment scopes and configuration possibilities described in this brochure with respect to the standard equipment and special options for individual machines may differ from country to country. Please check out the standard equipment and special options available in your country with your local EMCO-TEST dealer in advance. Please note at all times: The systems function only within the system limits and support the customer in hardness testing. The responsibility for compliance with national standards and laws remains with the operator of the hardness testing machine.

# Benefit from our worldwide sales and service network!



More on [emcotest.com](http://emcotest.com)

**EMCO-TEST**

EMCO-TEST Prüfmaschinen GmbH

Kellau 174

5431 Kuchl-Salzburg/Austria

[office@emcotest.com](mailto:office@emcotest.com)

[www.emcotest.com](http://www.emcotest.com)

Tel. +43 6244 204 38

Fax +43 6244 204 38-8

